

### FEATURES

- Three Ignition Advance Angles (Start, Idle, and Run Zones)
- Works in Magneto-based and CDI Systems
- RC Oscillator
- Schmitt Trigger Inputs for Noise Immunity
- Ignition Output Driver for SCR
- RPM Limiter
- Operating Voltage: 2.7V – 5.5V
- Operating Temperature: -40°C to 125°C
- Package: 8-pin SOIC

### GENERAL DESCRIPTION

The KX1130 is an electronic ignition controller for small gasoline engines. The KX1130 provides variable ignition timing by selecting one of three ignition advance angles based on engine speed. Variable timing provides better cold start performance as well as higher efficiency when running at high engine speeds.

Using an RC oscillator time base, the KX1130 measures the time between pulses from the magneto to determine the speed of the engine. Based on the engine speed, the KX1130 calculates the appropriate delay to position the ignition pulse at the desired advance angle.

### FUNCTIONAL BLOCK DIAGRAM

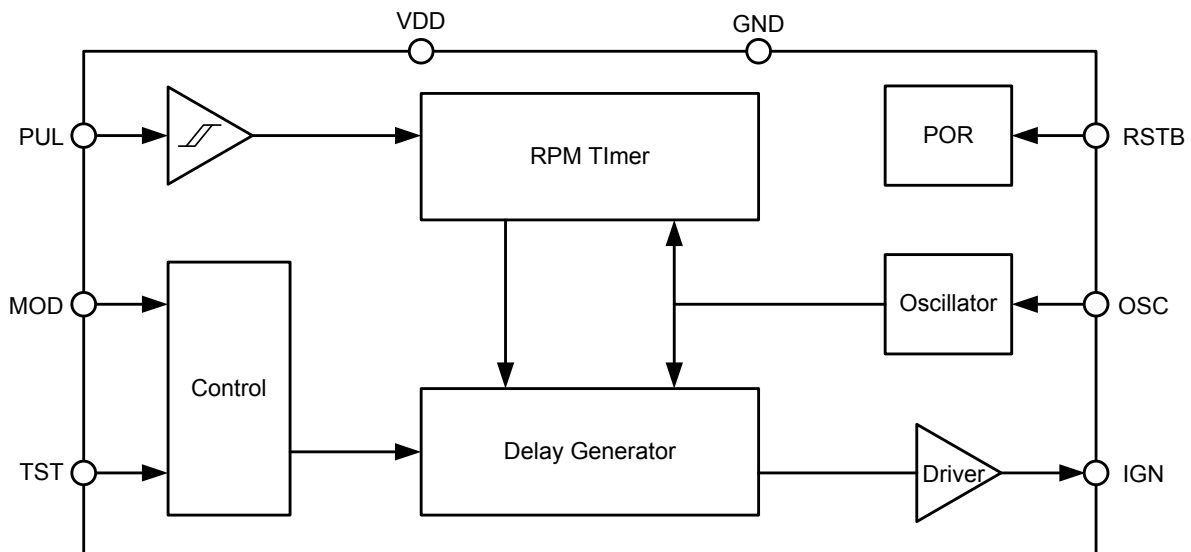

# KX1130 Ignition Controller

---

## EXAMPLE APPLICATION CIRCUIT

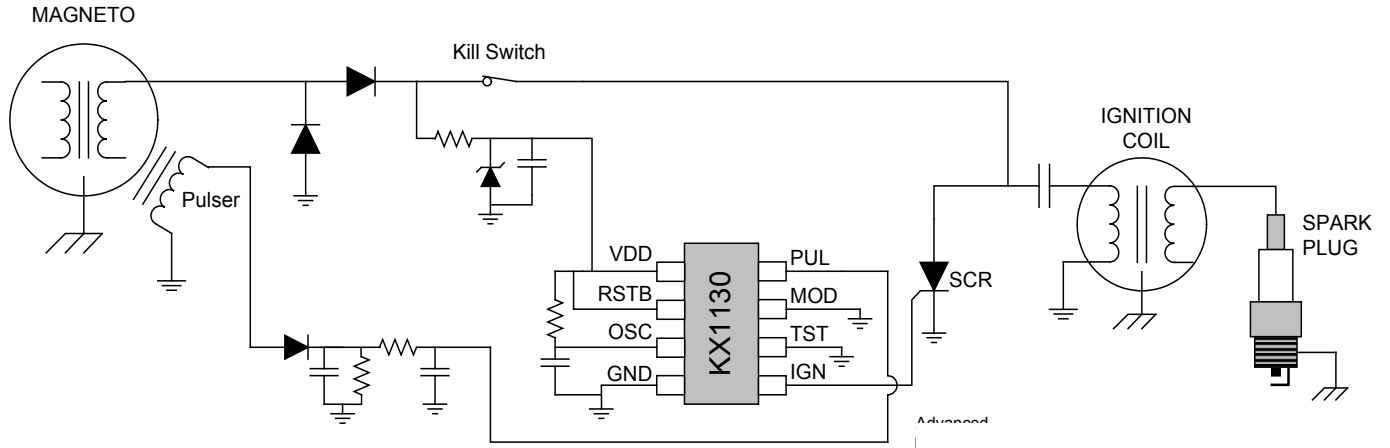

## Contact Information

**Keterex, Inc.**  
**7320 N. Mo Pac Expressway**  
**Suite 201**  
**Austin, Texas 78731**  
**Tel: 512-346-8800**  
**www.keterex.com**  
**Email: sales@keterex.com**

Information furnished by Keterex, Inc. in this document is believed to be accurate and reliable. However, no responsibility is assumed for its use. Information in this document is subject to change without notice.

**Trademarks:** The Keterex name and logo are registered trademarks of Keterex Incorporated. Other products or brand names mentioned herein are trademarks or registered trademarks of their respective holders.